



CW-18 (CWO-1800) Circle Welder

For welding diameters from 10" to 50"
(250 - 1270 mm) O.D.

Use with 3 jaw expandable chuck
or manipulator.

Features:

- Wire feeder with one set of drive rolls.
- DC drive motor and speed control for rotation.
- Meter kit with 0-50 DC volt meter, 0-600 DC amp meter.
- Gun and cable assembly
- Nozzle flux cone.
- Burnback control.
- 50 ft. (15 m) control cable.
- Weld switch, manual - automatic.
- Cold wire inch switch.
- Wire direction switch.
- Torch angle adjustor.
- Flux hopper with gate valve.
- 60 lbs. (27 kg) wire reel.
- Horizontal and Vertical adjustment by rack and pinion.
- Rise and fall slide assembly.
- Rise and fall cam with 7" (175 mm) of travel.
- Brushes and collector rings for welding current, rated at 600 amps 100% duty cycle.

Technical Data:

CW-18 (CWO-1800)

| | |
|-------------------------|------------------------|
| Input Voltage: | 115 VAC |
| Duty Cycle: | 100% |
| Amperage: | 0-600 amps |
| Voltage: | 0-50 |
| Wire Sizes: | .035-.7/32 (0.8-5.6mm) |
| Rotation Speed: | .06-.72 rpm |
| Cam Range: | 0"-7" (0-175 mm) |
| Welding Radius: | 0"-25" (0-635 mm) |
| Shielding Gas: | Solenoid Control |
| Height: | 43" (1092 mm) |
| Net Weight: | 360lbs. (163.6 kg) |
| Shipping Weight: | 490 lbs. (222.3 kg) |

The CW-18 may be used with any constant voltage power source with connections for 115 VAC and weld contactor.

Options:

Horizontal and vertical adjustment may be motorized.

Gas option for MIG and flux cored welding is available.

Three jaw expandable chucks.

Flux Recovery System.

SIDE ELEVATION

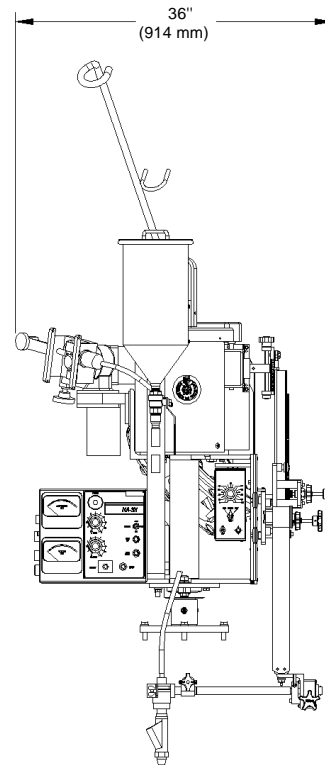

FRONT ELEVATION

