

ProArc ServoArc Welding System

▶▶ CB-500 & CB-600 controller

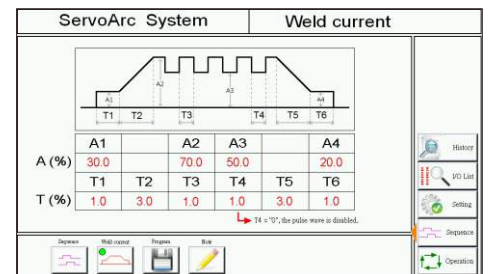
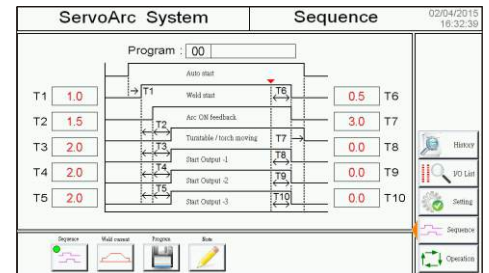

● Sequence setting

To facilitate welding automation, ProArc introduces the new ServoArc control system, CB-500.

The entire ServoArc series employ **SERVO MOTOR** to achieve a more stable and accurate welding process. ServoArc series integrated with CB-500 or CB-600 controller provide the best welding experience.

User can easily preset welding process, welding speed and current through intuitive HMI. The newly added remote pendant provides on-line welding process modification.

Features

- Quality : Product with performance.
- Efficiency : Save/load welding parameters for rapid welding preparation.
- Reliability : Welding sequence and welding current can be saved.
- Convenience : Set all welding parameters on controller.
- Easy : Programmable logic controller with touch panel and remote pendant.
- Powerful : Connect any welder by 0-10V analog interface
- Accuracy : Positioning accuracy within 0.1mm, and speed accuracy within 0.01%
- High speed dynamic range (up to 1000), stable welding speed pair with fast positioning speed for decreasing cycle time.

CB-500 Controller

▶▶ for single ServoArc unit

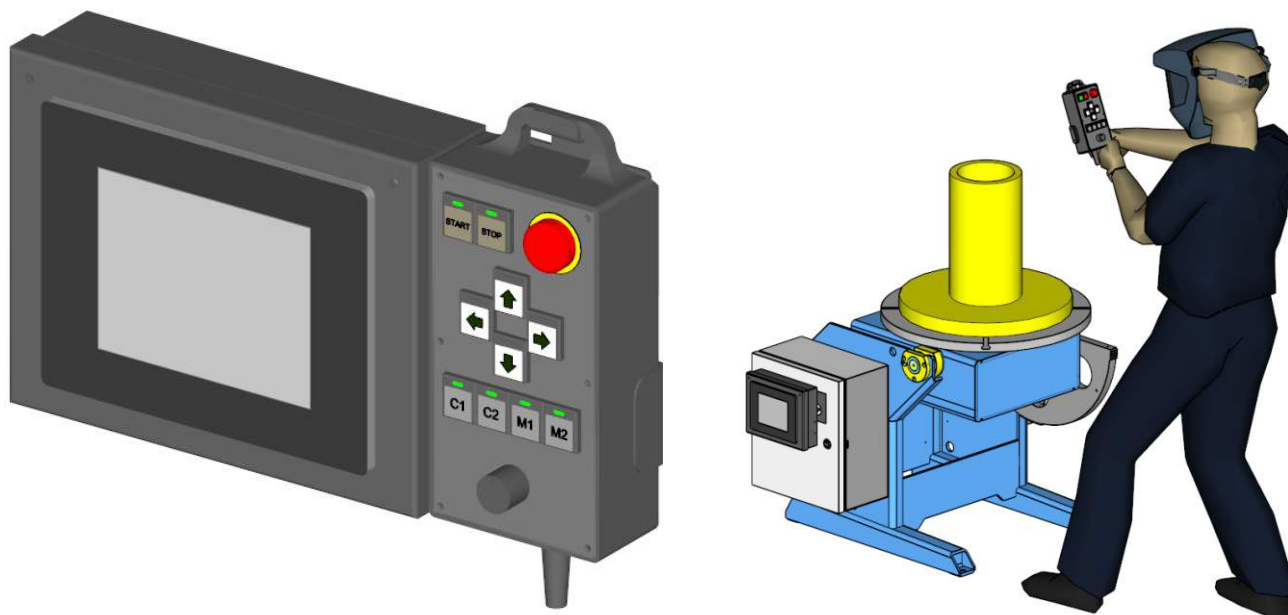

CB-500 controller can accurately perform welding procedure to the millisecond. Combined with an intuitive 7" HMI, user can easily preset and edit welding process parameters. The addition of remote pendant provides on-line welding speed overwrite and welding process modification (i.e. welding current or welding voltage).

CB-500 can also accommodate different welding power source including metal inner gas welding(MIG), tungsten inert gas welding(TIG), submerged arc welding(SAW), and plasma arc welding(PAW).

CB-500 can control any single ServoArc machine, i.e. control manipulator (MP) or side-beam (SB) to perform basic longitudinal welding; control positioner (PT), turn table (TT), or head&tail stock (HTS) to perform circumferential and step circumferential welding.

Features

- Robust PLC.
- Intuitive 7" HMI.
- Easy to use remote pendant.
- Accurate process timing.
- Save/load welding parameters for rapid welding preparation..
- 0-10V analog interface for welding power source current control.
- Positioning accuracy within 0.1mm provides accurate welding distance.
- Speed accuracy within 0.01% offer excellent welding performance.

Application

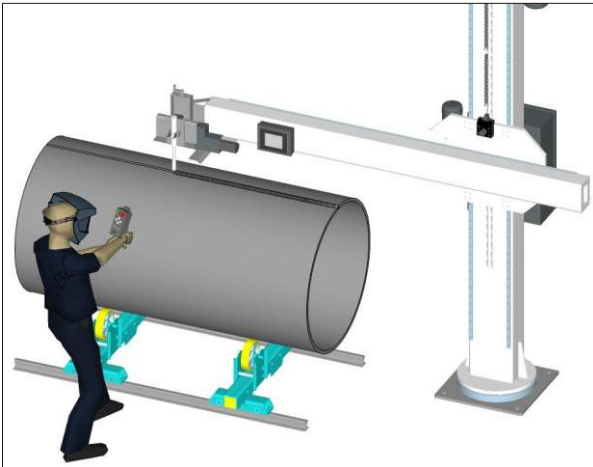

- ServoArc system: MP-20LS manipulator controlled by CB-500. The remote pendant allows user to adjust welding current and welding speed online (during welding).

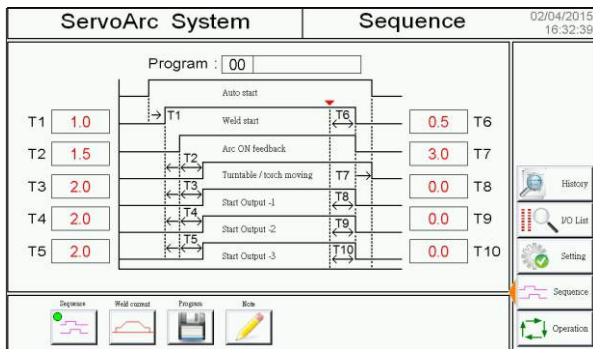

- Sequence setting



- ServoArc system: PT-750S positioner with CB-500 controller.

Specification

Specification		
Power Requirement		100~240VAC, 50/60Hz
Operation Temperature	° C	0~50° C
Operation Humidity	%	50~95%
Storage Temperature	° C	-20~60° C
HMI Display Size		7", 65536 color, 320 x 234 res
HMI Box Dimension	mm	230 x 180 x 69
Remote Pendant Dimension	mm	100 x 250 x 69
Maximum Servo Arc System Supported		1

*Specifications subject to change without notice

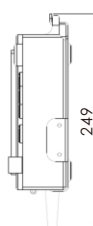
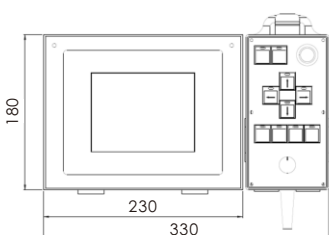

CB-600 Controller

▶▶ for 1 + 1 ServoArc unit

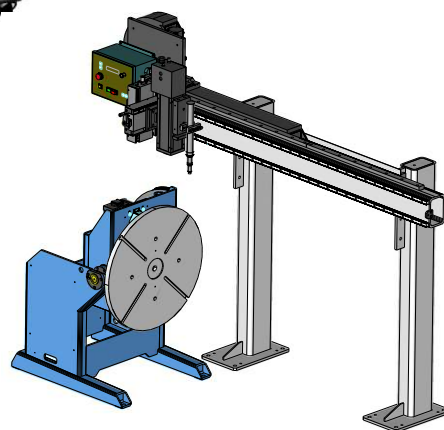
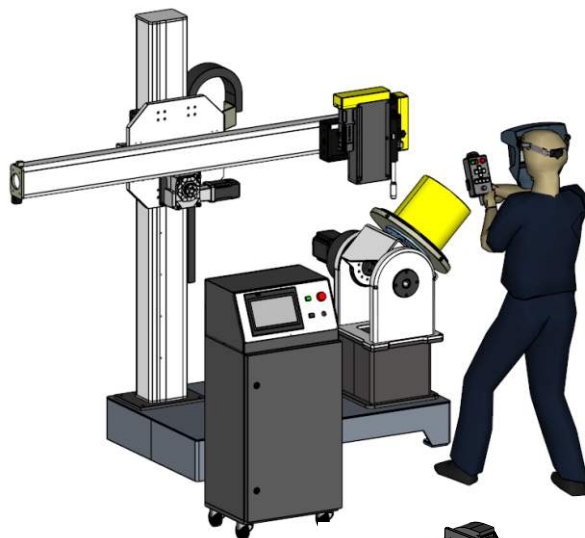
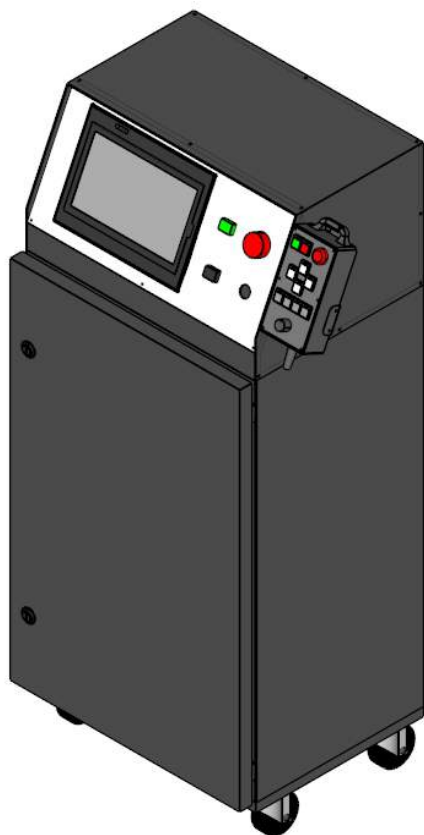

CB-600 controller is designed for integrating with **two ServoArc series** together to perform Longitudinal, Circumferential, and Spiral welding.

CB-600 controller can also accommodate different welding power source and welding process including metal inner gas (MIG) welding, tungsten inert gas (TIG) welding, submerged arc (SAW) welding, or plasma arc (PAW) welding.

Features

- CB-600 controller can control two ServoArc machines and welder on HMI.
- Programmable logic controller and intuitive 10" HMI for easy operation.
- Remote pendant interface provide on-line welding speed overwrite and welding welding current or voltage overwrite.
- Accurate process timing.
- Save/load welding parameters for rapid welding preparation.
- 0-10V analog interface for welding power source current control.
- Positioning accuracy within 0.1mm provides accurate welding distance.
- Speed accuracy within 0.01% offer excellent welding performance.

Application

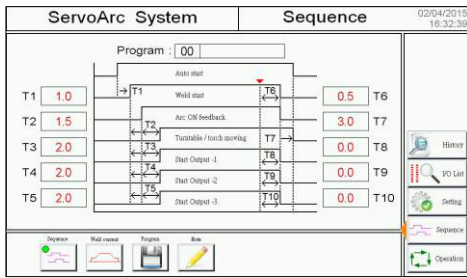

- Combined ServoArc system: **Manipulator + Positioner + CB-600 controller**. Operator control the rotation speed and welding current during operation.

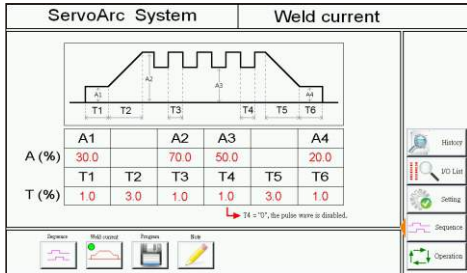

- Sequence setting



Specification

Specification		
Power Requirement		100~240VAC, 50/60Hz
Operation Temperature	° C	0~50° C
Operation Humidity	%	50~95%
Storage Temperature	° C	-20~60° C
HMI Display Size		10.4", 65,536 color, 800 x 480 res
HMI Box Dimension	mm	500 x 400 x 1,180
Remote Pendant Dimension	mm	100 x 250 x 69
Maximum Servo Arc System Supported		2

*Specifications subject to change without notice

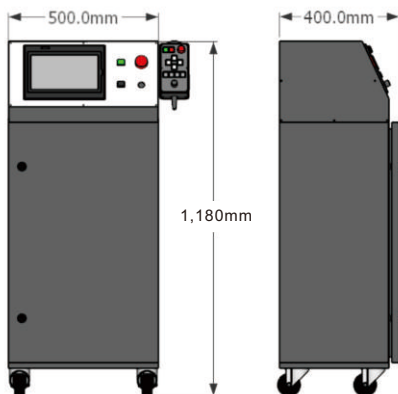

Welding Equipment

CB-500 controller is integrated with single unit: **Manipulator, Positioner, Side-Beam, Head&Tail Stock and Turn Table.**

CB-600 controller is integrated with pair units: **Manipulator + Positioner, Manipulator + Turn Table, SideBeam + Positioner, SideBeam + Turn Table, SideBeam + Head&Tail Stock.**

	CB-500	CB-600
Manipulator	O	
Positioner	O	
Side-Beam	O	
Head&Tail Stock	O	
Turn Table	O	
Manipulator+Positioner		O
Manipulator+Turn Table		O
SideBeam + Positioner		O
SideBeam + Turn Table		O
SideBeam + Head&Tail Stock		O

*Specifications subject to change without notice

Function

	CB-500	CB-600
HMI	7" HMI	10" HMI
Remote Pendant	O	O
Welding Sequence Control	O	O
Welding Current Control	O	O
Save/Load Parameters	O	O
Manual Function	O	O
Positioning	O	O
Longitudinal Welding	O	O
Circumference Welding	O	O
Index Welding	O	O
User Defined Output *1	O	O
Horizontal Step Circumferential Welding		O
Vertical Step Circumferential Welding		O
Horizontal Spiral Welding		O
Vertical Spiral Welding		O

*1: user defined outputs for communication with optional welding system (i.e. oscillator or wire feeder)

*Specifications subject to change without notice