

Spray Master® V250 Amp MIG Gun

MIG GUNS



80% Duty Cycle - Mixed Gases
Suitable for Light/Medium Duty Fabrication.

WELDING PROCESSES:
**MIG (GMAW), Flux Cored (FCAW),
Aluminum (GMAW)**

Standard Options Include:

- Rear Connector and Knucklehead™ Flexible Conductor Tube
- Standard Conductor Tube – Part No. SMVCT-60 (Stock No.1240-1374) on all guns up to 15ft (4.6 m)
- Part No. SMVCT-45 (Stock No. 1240-1373) on all guns over 15ft (4.6 m)
- Conduit Liner – 42 Series

Tweco® Style Rear Connector

Adapter kits are available to fit Tweco rear connection to most wire feeders

Wire Size	Length	Part No.	Stock No.
Up To .045" (1.2 mm)	10 ft (3 m)	SMV210-3545	1023-1290
	12 ft (3.6 m)	SMV212-3545	1023-1276
	15 ft (4.6 m)	SMV215-3545	1023-1277
	20 ft (6.1 m)	SMV220-3545	1023-1278
	25 ft (7.6 m)	SMV225-3545	1023-1279

Lincoln® Style Rear Connector

Fits Lincoln LN7, 8, 9, SP200

Wire Size	Length	Part No.	Stock No.
Up To .045" (1.2 mm)	10 ft (3 m)	SMV210L-3545	1023-1292
	12 ft (3.6 m)	SMV212L-3545	1023-1285
	15 ft (4.6 m)	SMV215L-3545	1023-1293
	20 ft (6.1 m)	SMV220L-3545	1023-1294
	25 ft (7.6 m)	SMV225L-3545	1023-1295

Some Lincoln wire feeders are assembled with their K1500-2 gun receiving bushing that will accept Tweco Style MIG Guns direct from the factory. Control wire Part No. MS354-DSLJ (Stock No. 2060-2137) must be ordered separately.

Miller® Style Rear Connector

Wire Size	Length	Part No.	Stock No.
Up To .045" (1.2 mm)	10 ft (3 m)	SMV210M-3545	1023-1280
	12 ft (3.6 m)	SMV212M-3545	1023-1281
	15 ft (4.6 m)	SMV215M-3545	1023-1282
	20 ft (6.1 m)	SMV220M-3545	1023-1283
	25 ft (7.6 m)	SMV225M-3545	1023-1289

Euro-Kwik Style Rear Connector

Wire Size	Length	Part No.	Stock No.
Up To .045" (1.2 mm)	10 ft (3 m)	SMV210X-3545	1023-1286
	12 ft (3.6 m)	SMV212X-3545	1023-1287
	15 ft (4.6 m)	SMV215X-3545	1023-1288
	20 ft (6.1 m)	SMV220X-3545	1023-1291
	25 ft (7.6 m)	SMV225X-3545	1023-1284

For Special MIG gun configurations, including special consumables, please contact Tech Service and Support.

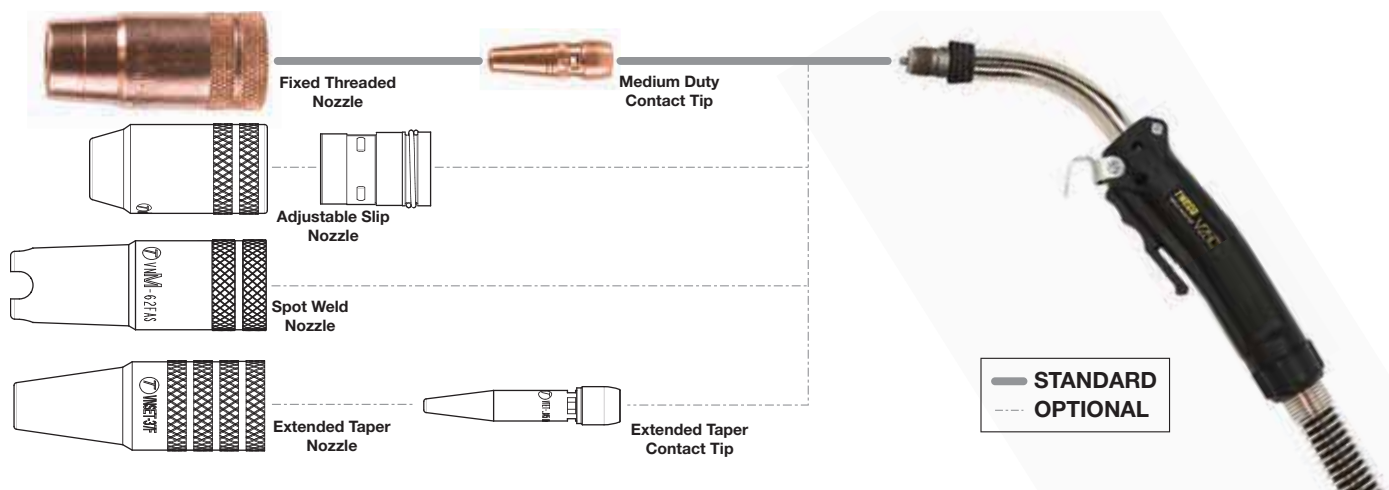

Rated Output			Wire Size	Cooled	Application Usage
Amps	Duty Cycle	Gas			
250 Amps	80%	Mixed	Up To .045" (1.2 mm)	Air	Light/Medium Duty Fabrication

For more information refer to Tweco Spray Master V-Series MIG Gun flyer Form No. 64-1404

EASY FIND
EASY FIND GUIDE
See Page 20 & 21 for Replacement Parts & Optional Accessories

Miller is a registered trademark of Illinois Tool Works, Inc. Lincoln is a registered trademark of Lincoln Electric Co. The aforementioned registered trademarks are in no way affiliated with Tweco. Tweco is registered trademark of ESAB.

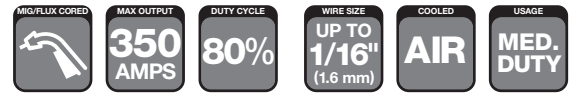

Spray Master® V350 Amp MIG Gun



80% Duty Cycle - Mixed Gases
Suitable for Medium/Heavy Duty Fabrication.

WELDING PROCESSES:
MIG (GMAW), Flux Cored (FCAW),
Aluminum (GMAW),

Standard Options Include:

- Dual Schedule On/Off Control, Rear Connector and Knucklehead™ Flexible Conductor Tube
- Standard Conductor Tube – Part No. SMVCT-60 (Stock No.1240-1374) on all guns up to 15ft (4.6 m)
- Part No. SMVCT-45 (Stock No. 1240-1373) on all guns over 15ft (4.6 m)
- Conduit Liner – 42 Series

MIG GUNS

Tweco® Style Rear Connector

Adapter kits are available to fit Tweco rear connection to most wire feeders

Wire Size	Length	Part No.	Stock No.
Up To 1/16" (1.6 mm)	10 ft (3 m)	SMV310-116	1036-1750
	12 ft (3.6 m)	SMV312-116	1036-1752
	15 ft (4.6 m)	SMV315-116	1036-1756
	15 ft (4.6 m)	SMV315-116DSRS	1036-1783
	15 ft (4.6 m)	SMV315-116K4	1036-1759
	20 ft (6.1 m)	SMV320-116	1036-1789
	25 ft (7.6 m)	SMV325-116	1036-1787

Lincoln® Style Rear Connector

Fits Lincoln LN7, 8, 9, SP200

Wire Size	Length	Part No.	Stock No.
Up To 1/16" (1.6 mm)	10 ft (3 m)	SMV310L-116	1036-1785
	12 ft (3.6 m)	SMV312L-116	1036-1753
	15 ft (4.6 m)	SMV315L-116	1036-1762
	15 ft (4.6 m)	SMV315L-116DSRS	1036-1788
	15 ft (4.6 m)	SMV315L-116K4	1036-1764
	20 ft (6.1 m)	SMV320L-116	1036-1781
	25 ft (7.6 m)	SMV325L-116	1036-1786

Some Lincoln wire feeders are assembled with their K1500-2 gun receiving bushing that will accept Tweco Style MIG Guns direct from the factory. Control wire Part No. MS354-DSLJ (Stock No. 2060-2137) must be ordered separately.

Miller® Style Rear Connector

Wire Size	Length	Part No.	Stock No.
Up To 1/16" (1.6 mm)	10 ft (3 m)	SMV310M-116	1036-1751
	12 ft (3.6 m)	SMV312M-116	1036-1754
	15 ft (4.6 m)	SMV315M-116	1036-1765
	15 ft (4.6 m)	SMV315M-116K4	1036-1768
	15 ft (4.6 m)	SMV315M-332K4	1036-1791
	15 ft (4.6 m)	SMV315M-116CT180	1036-1777
	20 ft (6.1 m)	SMV320M-116	1036-1780
	25 ft (7.6 m)	SMV325M-116CT180	1036-1778
	25 ft (7.6 m)	SMV325M-116	1036-1775

Euro-Kwik Style Rear Connector

Wire Size	Length	Part No.	Stock No.
Up To 1/16" (1.6 mm)	10 ft (3 m)	SMV310X-116	1036-1784
	12 ft (3.6 m)	SMV312X-116	1036-1779
	15 ft (4.6 m)	SMV315X-116	1036-1770
	20 ft (6.1 m)	SMV320X-116	1036-1782
	25 ft (7.6 m)	SMV325X-116	1036-1790

"DSRS" = Dual Schedule Rocker Switch; "K4" = Knucklehead Conductor Tube

For Special MIG gun configurations, including special consumables, please contact Tech Service and Support.

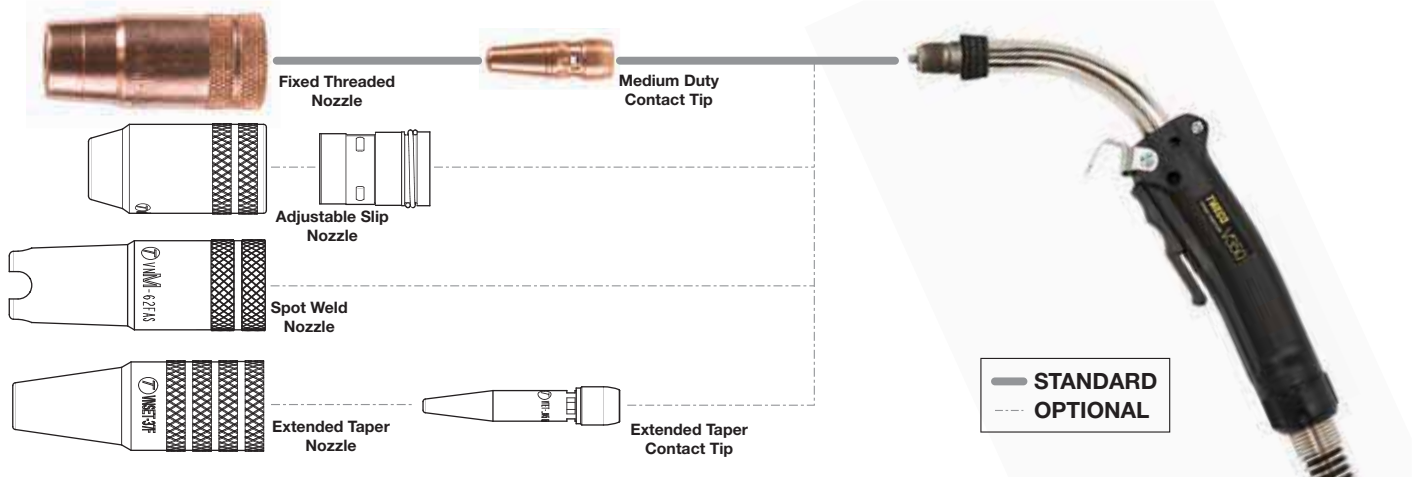

Rated Output			Wire Size	Cooled	Application Usage
Amps	Duty Cycle	Gas			
350 Amps	80%	Mixed	Up To 1/16" (1.6 mm)	Air	Medium/Heavy Duty Fabrication

EASY FIND GUIDE
See Page 20 & 21 for Replacement Parts & Optional Accessories

Miller is a registered trademark of Illinois Tool Works, Inc. Lincoln is a registered trademark of Lincoln Electric Co. The aforementioned registered trademarks are in no way affiliated with Tweco. Tweco is registered trademark of ESAB.



Spray Master® V450 Amp MIG Gun



80% Duty Cycle - Mixed Gases
Suitable for Heavy Duty Fabrication.

WELDING PROCESSES:
MIG (GMAW), Flux Cored (FCAW),
Aluminum (GMAW)

Standard Options Include:

- Dual Schedule On/Off Control, Locking Trigger, Rear Connector and Knucklehead™ Flexible Conductor Tube
- Standard Conductor Tube – Part No. SMVCT-60 (Stock No.1240-1374) on all guns up to 15ft (4.6 m)
- Part No. SMVCT-45 (Stock No. 1240-1373) on all guns over 15ft (4.6 m)
- Conduit Liner – 44 Series

Tweco® Style Rear Connector

Adapter kits are available to fit Tweco rear connection to most wire feeders

Wire Size	Length	Part No.	Stock No.
Up To 1/16" (1.6 mm)	10 ft (3 m)	SMV410-116	1040-1825
	12 ft (3.6 m)	SMV412-116	1040-1829
	15 ft (4.6 m)	SMV415-116	1040-1833
	15 ft (4.6 m)	SMV415-116LM	1040-1838
	15 ft (4.6 m)	SMV425-116LMK4	1040-1870
	20 ft (6.1 m)	SMV420-116	1040-1854
	25 ft (7.6 m)	SMV425-116	1040-1859

Lincoln® Style Rear Connector

Fits Lincoln LN7, 8, 9, SP200

Wire Size	Length	Part No.	Stock No.
Up To 1/16" (1.6 mm)	10 ft (3 m)	SMV410L-116	1040-1826
	12 ft (3.6 m)	SMV415L-116	1040-1866
	15 ft (4.6 m)	SMV415L-116	1040-1839
	15 ft (4.6 m)	SMV415L-116DSRS	1040-1840
	15 ft (4.6 m)	SMV415L-116LC	1040-1842
	15 ft (4.6 m)	SMV415L-116LM	1040-1843
	15 ft (4.6 m)	SMV415L-116K4	1040-1875
	20 ft (6.1 m)	SM420L-116	1040-1869
	25 ft (7.6 m)	SMV425L-116	1040-1860
	25 ft (7.6 m)	SMV425L-116LM	1040-1871

Some Lincoln wire feeders are assembled with their K1500-2 gun receiving bushing that will accept Tweco Style MIG Guns direct from the factory. Control wire Part No. MS354-DSLJ (Stock No. 2060-2137) must be ordered separately.

Miller® Style Rear Connector

Wire Size	Length	Part No.	Stock No.
Up To 1/16" (1.6 mm)	10 ft (3 m)	SMV410M-116	1040-1827
	12 ft (3.6 m)	SMV412M-116	1040-1830
	15 ft (4.6 m)	SMV415M-116	1040-1844
	15 ft (4.6 m)	SMV415M-116DSRS	1040-1846
	15 ft (4.6 m)	SMV415M-116LC	1040-1848
	15 ft (4.6 m)	SMV415M-116LM	1040-1849
	15 ft (4.6 m)	SMV415M-116K4	1040-1874
	20 ft (6.1 m)	SMV420M-116	1040-1855
	25 ft (7.6 m)	SMV425M-116	1040-1861
	25 ft (7.6 m)	SMV425M-116LM	1040-1872

Euro-Kwik Style Rear Connector

Wire Size	Length	Part No.	Stock No.
Up To 1/16" (1.6 mm)	10 ft (3 m)	SMV410X-116	1040-1828
	12 ft (3.6 m)	SMV412X-116	1040-1832
	15 ft (4.6 m)	SMV415X-116	1040-1850
	20 ft (6.1 m)	SMV420X-116	1040-1867
	25 ft (7.6 m)	SMV425X-116	1040-1868
	25 ft (7.6 m)	SMV425X-116LM	1040-1873

"DSRS" = Dual Schedule Rocker Switch; "LC" = Locking Trigger;
"K4" = Knucklehead Conductor Tube; "LM" = Long reach Conductor Tube

For Special MIG gun configurations, including special consumables, please contact Tech Service and Support.

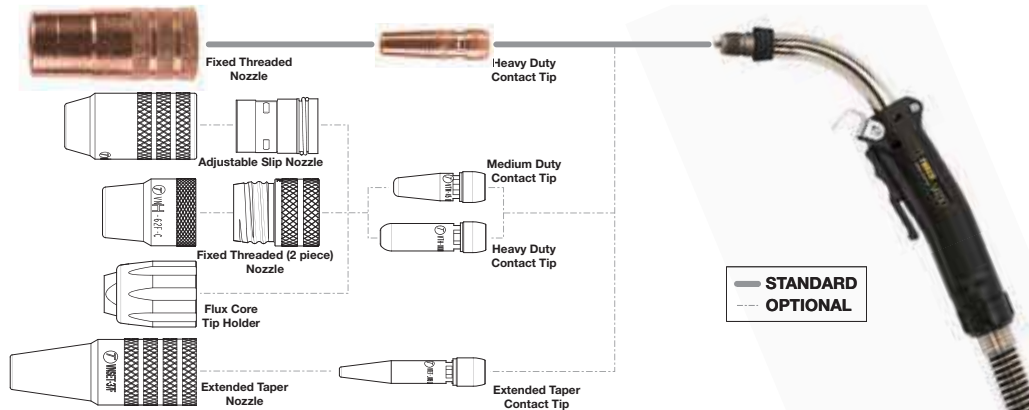

Rated Output			Wire Size	Cooled	Application Usage
Amps	Duty Cycle	Gas			
450 Amps	80%	Mixed	Up To 1/16" (1.6 mm)	Air	Heavy Duty Fabrication



Miller is a registered trademark of Illinois Tool Works, Inc. Lincoln is a registered trademark of Lincoln Electric Co. The aforementioned registered trademarks are in no way affiliated with Tweco. Tweco is registered trademark of ESAB.