

# Smoke Master® 250 Amp Fume Extraction Air-Cooled MIG Gun

MIG GUNS



**60% Duty Cycle - CO<sub>2</sub> Carbon Dioxide**  
Suitable for Light to Medium Duty Fabrication.

**WELDING PROCESSES:**  
MIG (GMAW), Flux Cored (FCAW),  
Aluminum (GMAW)

**Standard Options Include:**

- Rear Connector
- Standard Conductor Tube – Part No. 62-60 (Stock No. 2020-2006) on all guns up to 15 ft (4.6 m)
- Conduit Liner – 42 Series

## Tweco® Style Rear Connector

Adapter kits are available to fit Tweco rear connection to most wire feeders

Wire Size	Length	Part No.	Stock No.
Up To .045" (1.2 mm)	12 ft (3.6 m)	S212-4045	1026-1101
	15 ft (4.6 m)	S215-4045	1026-1102

## Lincoln® Style Rear Connector

Fits Lincoln LN7, 8, 9, SP200

Wire Size	Length	Part No.	Stock No.
Up To .045" (1.2 mm)	15 ft (4.6 m)	S215L-4045	1026-1132

Some Lincoln wire feeders are assembled with their K1500-2 gun receiving bushing that will accept Tweco Style MIG Guns direct from the factory. Control wire Part No. MS354-DSLJ (Stock No. 2060-2137) Must be ordered separately.

## Miller® Style Rear Connector

Wire Size	Length	Part No.	Stock No.
Up To .045" (1.2 mm)	12 ft (3.6 m)	S212M-4045	1026-1106
	15 ft (4.6 m)	S215M-4045	1026-1107

## Euro-Kwik Style Rear Connector

Wire Size	Length	Part No.	Stock No.
Up To .045" (1.2 mm)	15 ft (4.6 m)	XS215-4045	1026-1127

### FEATURES

- **Handle Slide Valve** allows the operator to regulate vacuum on the MIG gun
- **Efficiently Removes 90% of Smoke** from the welding zone
- **Surrounding Air** is drawn over the front end consumables and conductor tube to keep cool
- **Tough Outer Jacket** made from leather protecting inner vacuum hose from weld spatter/abrasion
- **Low Bench Weight** for easy to handle MIG gun
- **Spare Trigger Leads in Cablehoz**
- **Rugged & Durable Power Cablehoz®** with proven abrasion & heat resistance
- **Outer Metal Plated Insulated Smoke Tube**
- **1-3/8" (334.9 mm) Inside Diameter PVC Reinforced Vacuum Hose**
- **Ergonomic Handle** to reduce operator fatigue
- **Extended Trigger Length** to reduce radiated heat

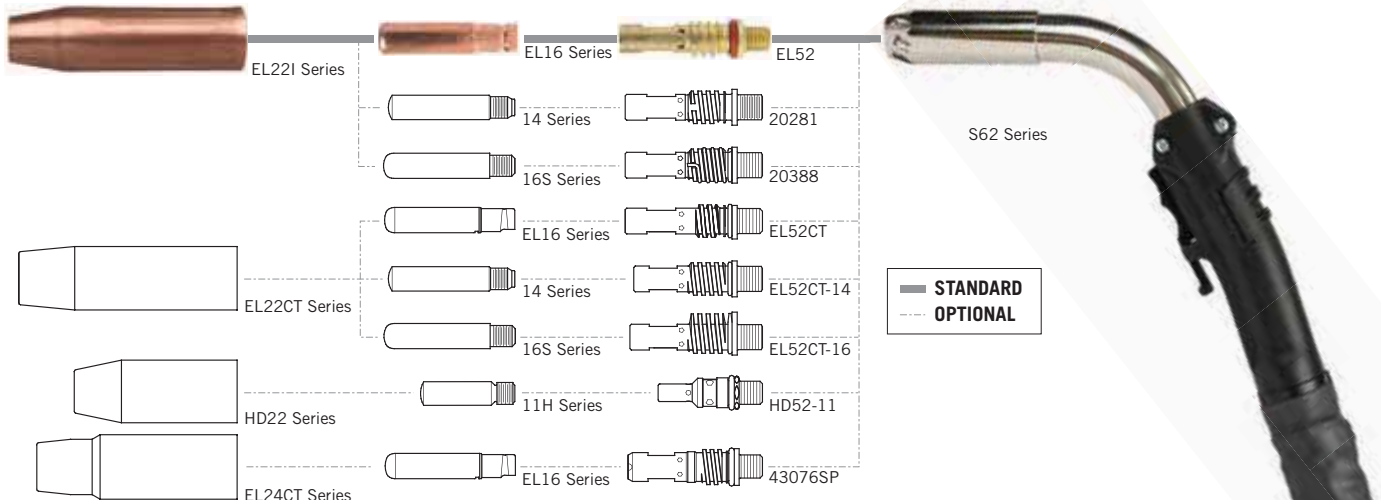

Rated Output			Wire Size	Cooled	Application Usage
Amps	Duty Cycle	Gas			
250 Amps	60%	CO <sub>2</sub> Carbon Dioxide	Up To .045" (1.2 mm)	Air	Medium Duty Fabrication

**EASY FIND**  
**EASY FIND GUIDE**  
See Page 72 for Replacement Parts & Optional Accessories

Miller is a registered trademark of Illinois Tool Works, Inc. Lincoln is a registered trademark of Lincoln Electric Co. The aforementioned registered trademarks are in no way affiliated with Tweco. Tweco is registered trademark of ESAB.

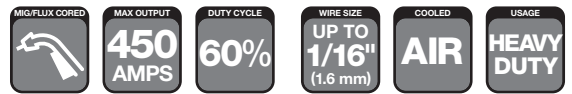

# Smoke Master® 450 Amp Fume Extraction Air-Cooled MIG Gun



**60% Duty Cycle - CO<sub>2</sub> Carbon Dioxide**  
Suitable for Medium to Heavy Duty Fabrication.

**WELDING PROCESSES:**  
MIG (GMAW), Flux Cored (FCAW), Aluminum (GMAW),

**Standard Options Include:**

- Rear Connector
- Standard Conductor Tube – Part No. S64-60 (Stock No. 1046-2258) on all guns up to 15 ft (4.6 m)
- Conduit Liner – 44 Series

MIG GUNS

## Tweco® Style Rear Connector

Adapter kits are available to fit Tweco rear connection to most wire feeders

Wire Size	Length	Part No.	Stock No.
Up To 1/16" (1.6 mm)	12 ft (3.6 m)	S412-116	1046-1105
	15 ft (4.6 m)	S415-116	1046-1108

## Lincoln® Style Rear Connector

Fits Lincoln LN7, 8, 9, SP200

Wire Size	Length	Part No.	Stock No.
Up To 1/16" (1.6 mm)	15 ft (4.6 m)	S415L-116	1046-1138

Some Lincoln wire feeders are assembled with their K1500-2 gun receiving bushing that will accept Tweco Style MIG Guns direct from the factory. Control wire Part No. MS354-DSLJ (Stock No. 2060-2137) Must be ordered separately.

## Miller® Style Rear Connector

Wire Size	Length	Part No.	Stock No.
Up To 1/16" (1.6 mm)	12 ft (3.6 m)	S412M-116	1046-1125
	15 ft (4.6 m)	S415M-116	1046-1128

### FEATURES

- **Handle Slide Valve** allows the operator to regulate vacuum on the MIG gun
- **Efficiently Removes 90% of Smoke** from the welding zone
- **Surrounding Air** is drawn over the front end consumables and conductor tube to keep cool
- **Tough Outer Jacket** made from leather protecting inner vacuum hose from weld spatter/abrasion
- **Low Bench Weight** for easy to handle MIG gun
- **Spare Trigger Leads in Cablehoz®**
- **Rugged & Durable Power Cablehoz®** with proven abrasion & heat resistance
- **Outer Metal Plated Insulated Smoke Tube**
- **1-3/8" (334.9 mm) Inside Diameter PVC Reinforced Vacuum Hose**
- **Ergonomic Handle** to reduce operator fatigue
- **Extended Trigger Length** to reduce radiated heat

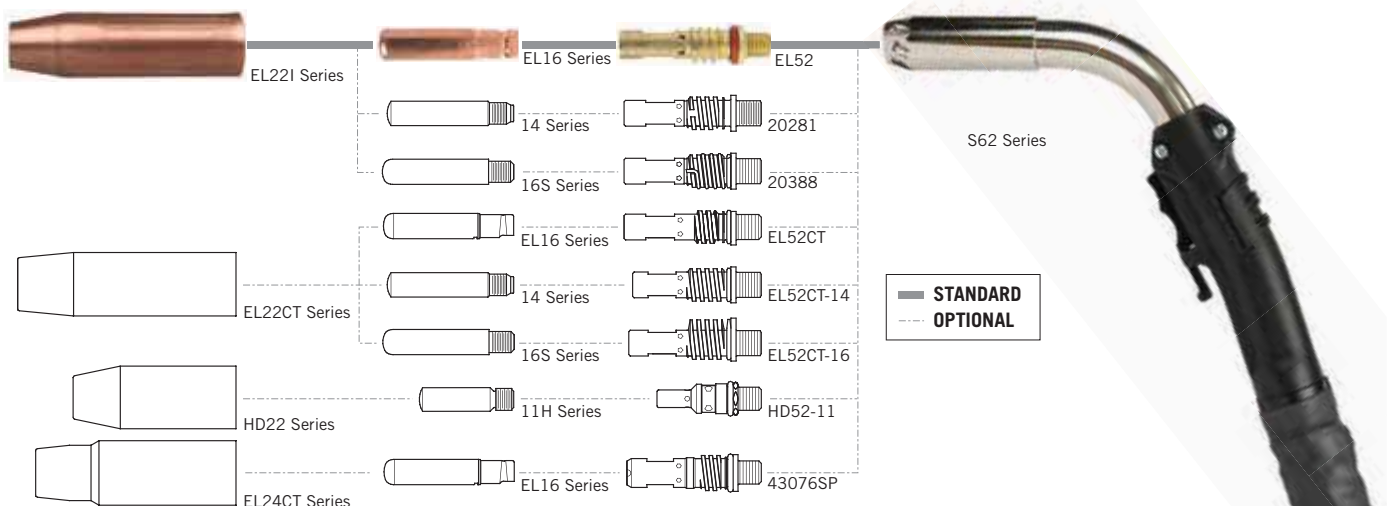

Rated Output			Wire Size	Cooled	Application Usage
Amps	Duty Cycle	Gas			
450 Amps	60%	CO <sub>2</sub> Carbon Dioxide	Up To 1/16" (1.6 mm)	Air	Heavy Duty Fabrication



Miller is a registered trademark of Illinois Tool Works, Inc. Lincoln is a registered trademark of Lincoln Electric Co. The aforementioned registered trademarks are in no way affiliated with Tweco. Tweco is registered trademark of ESAB.

# Smoke Master® Fume Extraction Air-Cooled MIG Gun Replacement Parts

MIG GUNS

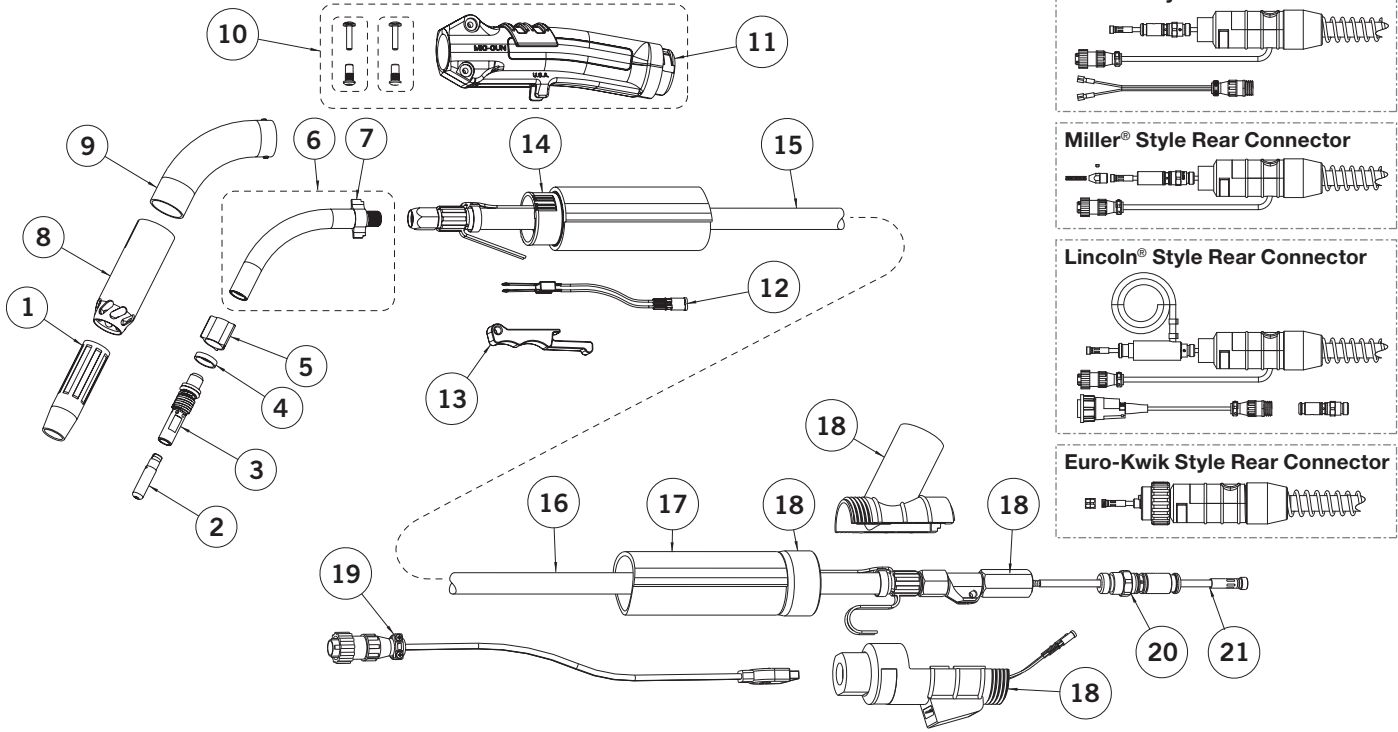

#	Description	250 Amp		450 Amp	
		Part No.	Stock No.	Part No.	Stock No.
1	Nozzle	EL221 Series		EL221 Series	
2	Contact Tip	EL16 Series		EL16 Series	
3	Diffuser (Slip-On)	EL52	1560-1110	EL52	1560-1110
	Diffuser (Coarse Thread)	EL52CT	1560-1109	EL52CT	1560-1109
4	Insulator Spacer	S62-60-2	2020-2013	S64-R	1046-2223
5	Smoke Tube Spacer	S62-60-2	2020-2013	S64-1	1046-2273
6	Conductor Tube (60 Degree, Standard)	S62-60	2020-2006	S64-60	1046-2258
	Conductor Tube (45 Degree, Standard)	S62-45	2020-2011	--	--
7	Handle Spacer	--	--	S64-2	1046-2271
8	Smoke Nozzle (Standard)	S22-62L	2020-2010	S24-62	1046-2225
	Smoke Nozzle (High Volume)	--	--	S24-62HV	1046-2226
9	Smoke Tube (60 Degree, Standard)	S62T-60	2020-2001	S64T-60	1046-2240
	Smoke Tube (45 Degree)	S62T-45	2020-2012	--	--
10	Handle Assembly	S82	2020-2003	S86	1046-2250
11	Handle Valve	S82-V	2020-2004	S86-V	1046-2252
12	Trigger Blade Assembly	ELC94-BL	2060-2671	ELC94-BL	2060-2671
13	Trigger	ELC94	2060-2647	EL96	2060-2605
14	Swivel Cap Assembly	S82-C	2020-2005	S86-C	1046-2254
15	Cablehoz® Assembly, 12 ft (4 m)	S212	2020-2008	S412	1046-2203
	Cablehoz Assembly, 15 ft (5 m)	S215	2020-2009	S415	1046-2206
16	Smoke Hose, 12 ft (4 m)	S412-H	1046-2214	S412-H	1046-2214
	Smoke Hose, 15 ft (5 m)	S415-H	1046-2217	S415-H	1046-2217
17	Leather Jacket, 12 ft (4 m)	SHP-12	1046-2267	SHP-12	1046-2267
	Leather Jacket, 15 ft (5 m)	SHP-15	1046-2268	SHP-15	1046-2268
18	Rear Case Assembly	M6RC	2060-2018	M6RC	2060-2018
19	Control Wire (Tweco®)	MAK-354	2642-2460	MAK-354	2642-2460
	Control Wire (Miller®)	MSAK-354	2642-2470	MSAK-354	2642-2470
	Control Wire (Lincoln®)	LAK-354	2642-2450	LAK-354	2642-2450
20	Connector Plug	Refer to Pages 90-91		Refer to Pages 92-93	
21	Conduit Assembly	Refer to Pages 122-125		Refer to Pages 124-127	

Miller is a registered trademark of Illinois Tool Works, Inc. Lincoln is a registered trademark of Lincoln Electric Co. The aforementioned registered trademarks are in no way affiliated with Tweco. Tweco is registered trademark of ESAB.