

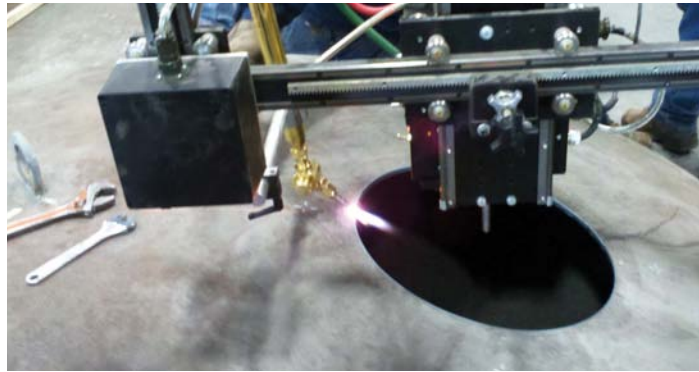

Programmable Circle Burners

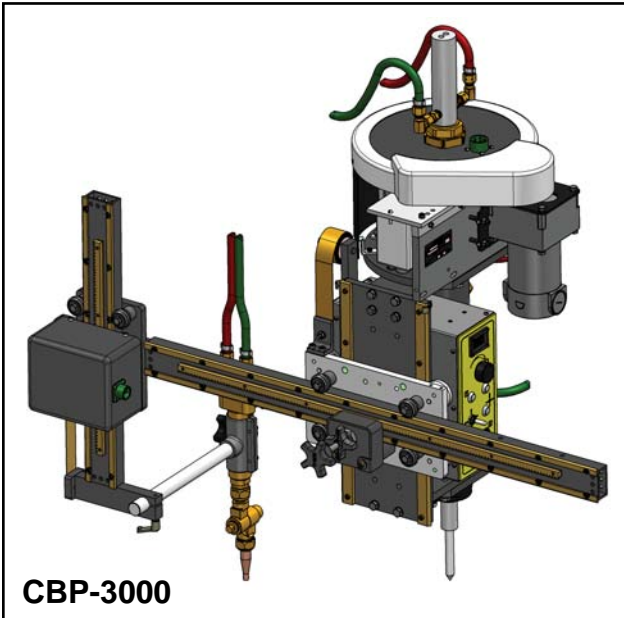

The **CBP-3 Programmable Circle Burner (CBP-3000)** must be mounted on a column and boom, manipulator or fixture. Uses Oxy-fuel for square or beveled hole cuts (see chart for capacities). Unit includes 2-hose oxy-fuel machine torch, adjustable tip adaptor, variable speed rotation, vertical and horizontal torch adjustment.

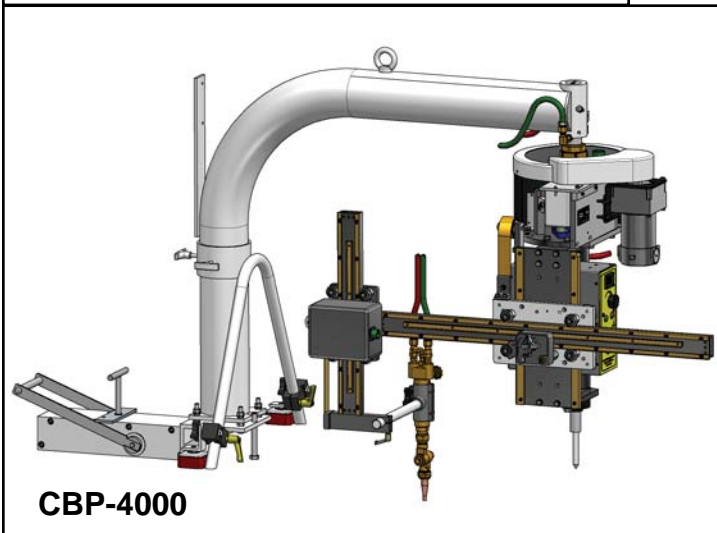

The **CBP-4 Programmable Circle Burner (CBP-4000)** is mounted on a special frame with a releasable permanent magnet base. Uses Oxy-fuel for square or beveled hole cuts (see chart for capacities). Machine includes variable speed rotation, 2-hose oxy-fuel machine torch, adjustable tip adaptor, vertical and horizontal torch adjustment.

Programmable Circle Burner Capacities

Model	Burning Diameter	Mounting	Process	Rise and Fall Cam	Net Weight	Use
CBP-3 CBP-3000	1.5"-42" beveled holes (38-1067 mm) 4"-48" square cut (102-1219 mm)	Carriage or Manipulator	Oxy-fuel	0-7" (0-178 mm)	170 lbs. (77 kg)	domed heads, vessels, large
CBP-4 CBP-4000	1.5"-42" beveled holes (38-1067 mm) 4"-48" square cut (102-1219 mm)	Manually Operated Magnet	Oxy-fuel	0-7" (0-178 mm)	225 lbs. (102 kg)	vessels, large diameter pipe