

# Multimatic™ 200

## MIG/Multiprocess Power Source, Wire Feeder and Gun Package



### Quick Specs

#### Light Industrial Applications

Light fabrication  
Maintenance and repair  
Mechanical contractor  
Construction

#### Processes

MIG (GMAW)  
Flux-cored (FCAW)  
DC TIG (GTAW)  
DC stick (SMAW)

#### Weld Thickness

**MIG:** 24 ga.–3/8 in. steel  
18 ga.–3/8 in. aluminum  
**TIG:** .020–3/16 in. steel  
**Stick:** 16 ga.–3/8 in. steel

#### Input Power

120 or 230 V

#### Input Hz

50/60 Hz

#### Input Phase

Single-phase

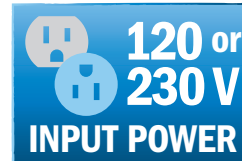

Uses 120- or 230-volt power



Portable

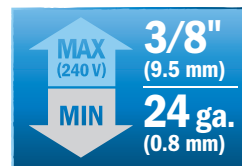

MIG weld capacity



Quick and easy setup

**Lightweight MIG, stick and TIG welder** weighs only 29 pounds (13.2) so it can go anywhere you need to weld.

**Auto-Set™ Elite** can be used on multiple materials and multiple processes with the ability to fine-tune your settings. Easy to set up and use.

**Impact-resistant case** provides strength and durability, protecting the internal components and welding wire.

**Excellent arc characteristics!** Multimatic 200 offers positive arc starts and an extremely stable arc with minimal spatter on both mixed gases and straight CO<sub>2</sub>.

**Multi-voltage plug (MVP™)** allows you to connect to common 120 or 230 V power receptacles without the use of any tools — choose the plug that fits the receptacle and connect it to the power cord.



**Optional spool guns.** Spoolmate™ 100 or 150 offer reliable and economical solutions for welding aluminum.

**Optional TIG contractor kit** gives you everything you need for remote TIG welding with the Multimatic 200.



Welder is warranted for three years, parts and labor.  
Gun warranted for six months, parts.

#### Comes complete with:

- Power source
- Power cord with MVP plugs for 120 and 230 V
- 10 ft. (3 m) Bernard™ Q150 MIG gun
- 13 ft. (4 m) cable with electrode holder and 25 mm Dinse-style connector
- 10 ft. (3 m) work cable with clamp and 25 mm Dinse-style connector
- Flow gauge regulator and gas hose for argon and AR/CO<sub>2</sub> mix
- Two contact tips for .030 in. (0.8 mm) wire, and two contact tips for .035 in. (0.9 mm) wire
- Quick Select™ drive roll for .024 in. (0.6 mm) or .030/.035 in. (0.8/0.9 mm) solid wire, and .030/.035 in. (0.8/0.9 mm) flux-cored wire
- Information/settings chart and quick setup guide
- Material thickness gauge ▶ 229895

*Note: Shielding gas and safety equipment not included.*



**Miller Electric Mfg. Co.**  
An ITW Welding Company  
1635 West Spencer Street  
P.O. Box 1079  
Appleton, WI 54912-1079 USA

**Equipment Sales US and Canada**  
Phone: 866-931-9730  
FAX: 800-637-2315  
International Phone: 920-735-4554  
International FAX: 920-735-4125

**MillerWelds.com**  
Facebook Twitter YouTube Instagram LinkedIn



# Specifications (Subject to change without notice.)



Welding Mode/ Process	Input Power	Welding Amperage Range	Rated Output	Amps Input at Rated Output, 50/60 Hz				Wire Feed Speed	Max. Open-Circuit Voltage	Dimensions	Net Weight
				120 V	230 V	KVA	KW				
CV: MIG/ flux-cored	120 V	30–140 A	90 A at 18.5 V, 60% duty cycle 110 A at 19.5 V, 20% duty cycle	18 22.4	—	2.2 2.7	2 2.6	70–425 ipm (1.8–10.8 m/min.)	90 VDC	H: 14.5 in. (368 mm) W: 9.75 in. (248 mm) D: 17 in. (432 mm)	29 lb. (13.2 kg)
	230 V	30–200 A	150 A at 21.5 V, 20% duty cycle	—	17.5	4.0	3.8				
CC: TIG	120 V	5–150 A	100 A at 14 V, 100% duty cycle 150 A at 16 V, 30% duty cycle	15.8 27	—	1.9 3.3	1.8 3.2	—	90 VDC (22–25 VDC*)		
	230 V	5–150 A	100 A at 14 V, 100% duty cycle 150 A at 16 V, 30% duty cycle	— —	8 13.8	1.9 3.2	1.7 3.0				
CC: Stick	120 V	20–100 A	70 A at 22.8 V, 100% duty cycle 100 A at 24 V, 35% duty cycle	16.5 24	—	2.0 2.9	1.9 2.8	—	90 VDC (22–25 VDC*)		
			100 A at 24 V, 100% duty cycle 150 A at 26 V, 30% duty cycle	— —	12.7 20.8	2.9 4.8	2.7 4.5				
	230 V	20–150 A	100 A at 24 V, 100% duty cycle 150 A at 26 V, 30% duty cycle	— —	12.7 20.8	2.9 4.8	2.7 4.5				

\*Sense voltage for stick and Lift-Arc™ TIG.

Certified by Canadian Standards Association to both the Canadian and U.S. Standards.

## Control Panel

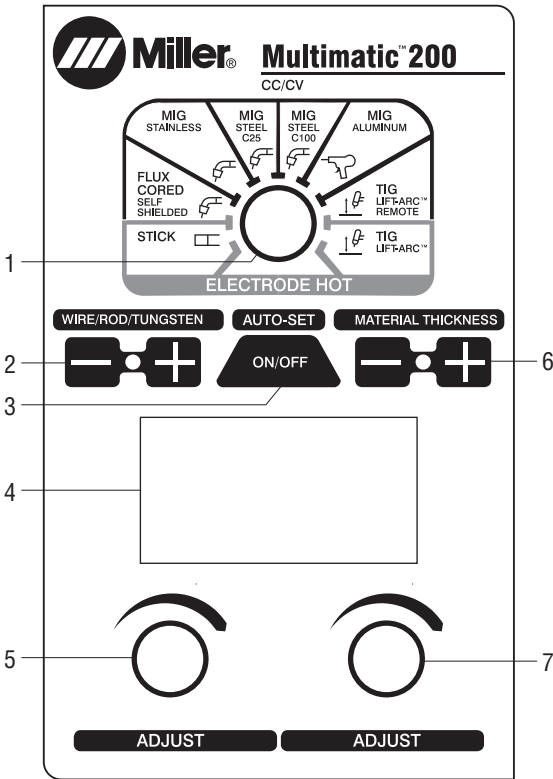

1. Process Selection Knob
2. Wire/Tungsten Diameter and Stick Rod Type Buttons
3. Auto-Set Button
4. LCD Display Panel
5. Adjustment Knob
6. Material Thickness Buttons
7. Adjustment Knob

## Performance Data

MIG Duty Cycle Chart

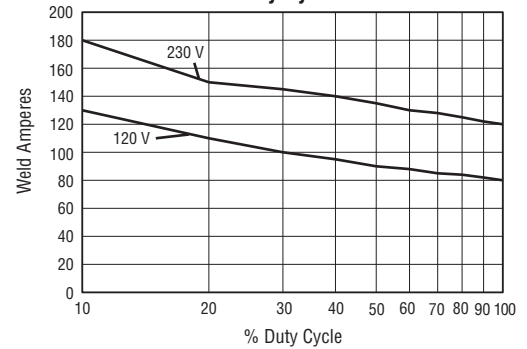

TIG Duty Cycle Chart

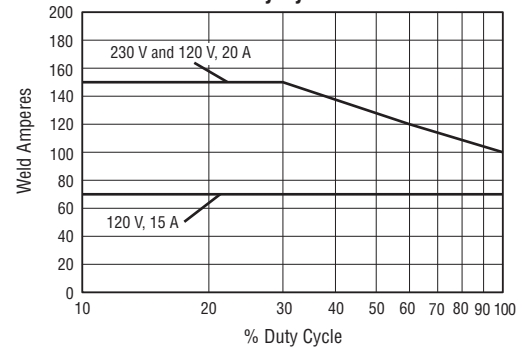

Stick Duty Cycle Chart

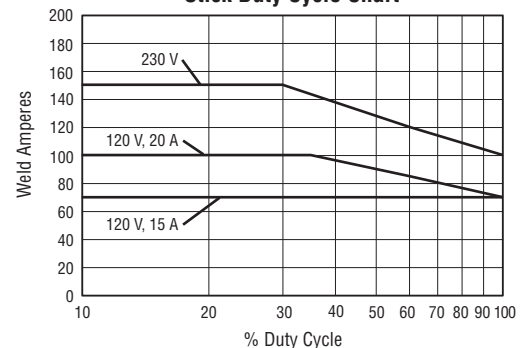

## Genuine Miller® Accessories

### Bernard™ Q150 Replacement Gun Q1510AB8BM 10 ft. (3 m)



**Spoolmate™ 100  
Spool Gun 300371**  
Direct-connect  
spool gun handles  
.030–.035 inch  
(0.8–0.9 mm)  
aluminum (4043 only)  
and .023–.035 inch

(0.6–0.9 mm) steel/stainless steel wires. Rated at 135 amps, 30-percent duty cycle. Includes 12-foot (3.7 m) cable assembly and custom carrying case.



**Spoolmate™ 150  
Spool Gun 301272**  
Direct-connect  
spool gun handles  
.030–.035 inch  
(0.8–0.9 mm)  
4000/5000 series  
aluminum and

.030–.035 inch (0.8–0.9 mm) steel/stainless steel wires. Rated at 150 amps, 60-percent duty cycle. Includes 20-foot (6.1 m) cable assembly.



### TIG Contractor Kit 301287

Kits comes complete with everything needed to TIG weld with the Multimatic 200. Includes Weldcraft™ A-150 TIG torch with Dinse-style connector, RFCS-6M foot control, flow gauge regulator with 12-foot (3.7 m) gas hose, and AK2C torch accessory kit.



### RCCS-6M Remote Contactor and Current Control 195184

North/south rotary-motion fingertip control attaches to TIG torch using two hook-and-loop fasteners. Includes 13.25-foot (4 m) cord and 6-pin plug.



### 14-Pin to 6-Pin Adapter Cord 300507

Adapts Miller 14-pin foot control or fingertip control to a 6-pin plug.



### Running Gear/ Cylinder Rack 301239

Heavy-duty construction with 8-inch rubber rear wheels. Convenient front handles, cable holders and plastic consumable box. For gas cylinders

no greater than 7 inches (178 mm) in diameter or 65 pounds (29.5 kg) in weight.

## MVP™ Plugs

Order from Miller Service Parts.



### 219258

For power cable 6-50P (230 V/50 A). Included with machine.



### 219261

For power cable 5-15P (115 V/15 A). Included with machine.



### 219259

For power cable 5-20P (115 V/20 A). Optional, not included with machine.

## Consumables (Order from Miller Service Parts.)

### For Q150 Gun

Insulator Cap 4323R

Gas Diffuser DS-1



### Contact Tips

**T-023** .024 in. (0.6 mm)

**T-030** .030 in. (0.8 mm)

**T-035** .035 in. (0.9 mm)



### Replacement Liners

**194010** .024 in.

**194011** .030–.035 in. (standard)

**194012** .035–.045 in.

15-foot length — trim to size needed.



**Nozzle NS-1200B**

### Self-Shielded Conversion Kit NS-FLX

Consists of tip holder 7010046, and insulators 7010024 and 7010059.



### Drive Rolls

#### Quick Select™ 261157

For .024-inch (0.6 mm) or .030/.035-inch (0.8/0.9 mm) solid wire, and .030/.035-inch (0.8/0.9 mm) flux-cored wire.

#### Dual Groove, V-Knurled 202926

For .030/.035-inch (0.8/0.9 mm) or .045-inch (1.2 mm) flux-cored wire.

### For Spoolmate™ 100 Spool Gun



**Contact Tips** (5 per package)

**199730** .024 in. (0.6 mm)

**186419** .030 in. (0.8 mm)

**186406** .035 in. (0.9 mm)



**Nozzle 186405**

### For Spoolmate™ 150 Spool Gun



**Contact Tips** (5 per package)

**199387** .030 in. (0.8 mm)

**199388** .035 in. (0.9 mm)



**Nozzle 050622**

### For Both Spool Guns



#### Drive Roll (1) 186413

For .030/.035-inch (0.8/0.9 mm) wire.



#### Push Roll (1) 186414

For .030/.035-inch (0.8/0.9 mm) wire.

## Ordering Information

Power Source and Options	Stock No.	Description	Qty.	Price
<b>Multimatic™ 200</b>	<b>907518</b>	120/230 V, 50/60 Hz		
<b>Multimatic™ 200 with TIG Contractor Kit</b>	<b>951649</b>	Power source packaged with 301287 TIG Contractor Kit		
<b>Guns</b>				
Bernard™ Q150 MIG Gun	<b>Q1510AB8BM</b>	10 ft. (3 m)		
Spoolmate™ 100 Spool Gun	<b>300371</b>	12 ft. (3.7 m). Includes custom carrying case		
Spoolmate™ 150 Spool Gun	<b>301272</b>	20 ft. (6.1 m)		
<b>Accessories</b>				
TIG Contractor Kit	<b>301287</b>	Includes Weldcraft™ A-150 TIG torch with Dinse-style connector, RFCS-6M foot pedal, flow gauge regulator with 12 ft. (3.7 m) gas hose, and AK2C torch accessory kit		
RCCS-6M Remote Control	<b>195184</b>	North/south fingertip control with 13.25 ft. (4 m) cord and 6-pin plug		
14-Pin to 6-Pin Adapter Cord	<b>300507</b>	Adapts Miller® 14-pin foot control or fingertip control to a 6-pin plug		
Running Gear/Cylinder Rack	<b>301239</b>			
Material Thickness Gauge	<b>229895</b>			
Flux-cored Wire				
Solid Wire				
Shielding Gas Cylinder				
Helmet/Gloves/Scratch Brush				
<b>Available Through Miller Service Parts</b>				
MVP™ Adapter Plug 230 V 6-50P	<b>219258</b>	Used to connect power source to 6-50R receptacle. Included with machine		
MVP™ Adapter Plug 115 V 5-15P	<b>219261</b>	Used to connect power source to 5-15R receptacle. Included with machine		
MVP™ Adapter Plug 115 V 5-20P	<b>219259</b>	Used to connect power source to 5-20R receptacle. Optional, not included with machine		
CO <sub>2</sub> Regulator/Flow Gauge	<b>237702</b>	Required if using 100 percent CO <sub>2</sub> gas		
Replacement Screen Cover	<b>231410</b>	Snap-in replacement cover for LCD screen		
Insulator Cap	<b>4323R</b>			
Gas Diffuser	<b>DS-1</b>			
Contact Tips		See page 3		
Replacement Liners		See page 3		
Nozzles		See page 3		
Self-Shielded Conversion Kit	<b>NS-FLX</b>	Consists of tip holder 7010046, and insulators 7010024 and 7010059		
Drive Rolls		See page 3		

Date:

Total Quoted Price:

Distributed by:

