

# Magicut table



SINCE 1966

The practical plasma and oxy-fuel cutting table



**Magicut** is the high competitive CNC metal plate cutting machine in its class.

It's easy to install, simple to operate, and with high efficient downdraft table.

## Features:

- MicroEDGE Pro control system
- Compactly designed structure convenient for installation and transportation
- 4'~6' cut width for plasma and oxy-fuel cutting
- Downdraft table with fantastic fume extraction efficiency



MicroEDGE Pro CNC controller

## Options:

- PC-005 Zinc powder for marking
- PC-007L Laser point positioning unit
- PC-024 Pneumatic sheet clamp
- PC-026 Mech. torch height control
- PC-047 Anti-collision device

Specification				
Model	Unit	Magicut 12	Magicut 15	Magicut 18
Power input		AC 220V, 50 / 60Hz, 3 phase		
Travel drive method		Rack & pinion		
Travel rail		Linear way & grinding plate		
Overall width (A)	mm	1,950	2,250	2,550
Overall height (B)	mm	1,600		
Overall length (C)	mm	3,550 (6,150)	4,150 (7,350)	
Cutting width (D)	mm	1,300	1,600	1,900
Cutting length (E)	mm	2,500 (5,000)	3,100 (6,200)	
Cutting speed	m/min	8		
Travel speed	m/min	12		
Max. cutting thickness	mm	50		
Number of torch		1 plasma + 1 flame (option)		
Machine weight	kg	1,450	1,570	1,750

\*Specifications subject to change without notice

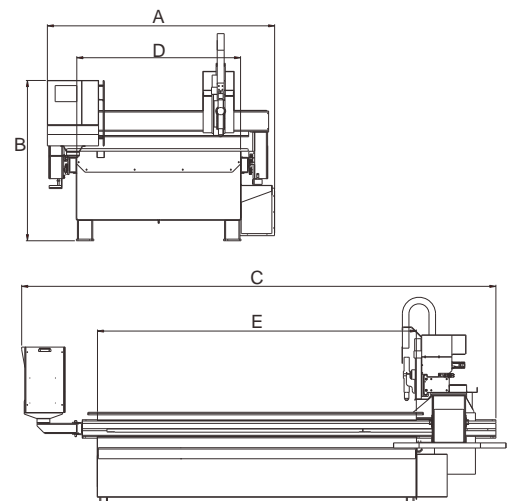

## UNITED PROARC CORPORATION

No.3 Gungye 10th Rd., Pingjen Industrial Park, Pingjen City, Taoyuan 32459, Taiwan  
 Phone: +886 3 469 6600 Fax: +886 3 469 4499  
 E-mail: sales@proarc.com.tw http://www.proarc.com.tw

*We love metal arts*

Welding · Cutting · Drilling · ..... since 1966