

MIG/MAG WELDING

trafimet
distribution

trafimet
welding & cutting

GPZ MEGA 2



7,6 m / 25'

V peak 113 **Ø** 0.6 ÷ 1.2
0.023" ÷ .045" **X** 60% 250A CO₂
200A Mix

Motor Voltage 24 V DC Wire speed 3÷20 m/min

CODE	↔	IS
MA1539	7,6 m / 25'	EURO
MA1541T	7,6 m / 25'	TWECO®
MA1541M	7,6 m / 25'	MILLER®
MA1541L	7,6 m / 25'	LINCOLN®

CODE	↔	IS
MA1541	7,6 m / 25'	5/8-18 UNF

Liner included

CODE	KIT
AR0170	Tweco® 1/4 KIT
AR0172	Lincoln® KIT
AR0173	Miller® KIT

Kit to be assembled by a qualified technician

TORCH + CONTROL BOX 110V - 115V

CODE	↔	IS
DM0040	7,6 m / 25'	EURO
DM0041	7,6 m / 25'	TWECO®
DM0042	7,6 m / 25'	MILLER®
DM0043	7,6 m / 25'	LINCOLN®

TORCH + CONTROL BOX 220V - 240V

CODE	↔	IS
DM0002	7,6 m / 25'	EURO

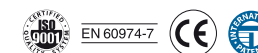
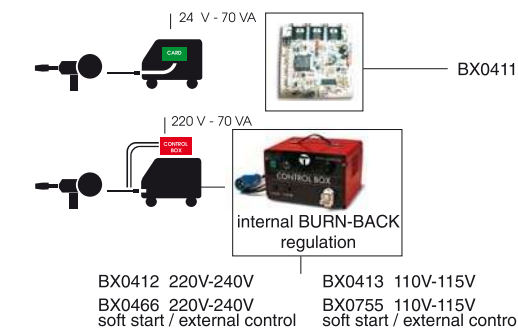

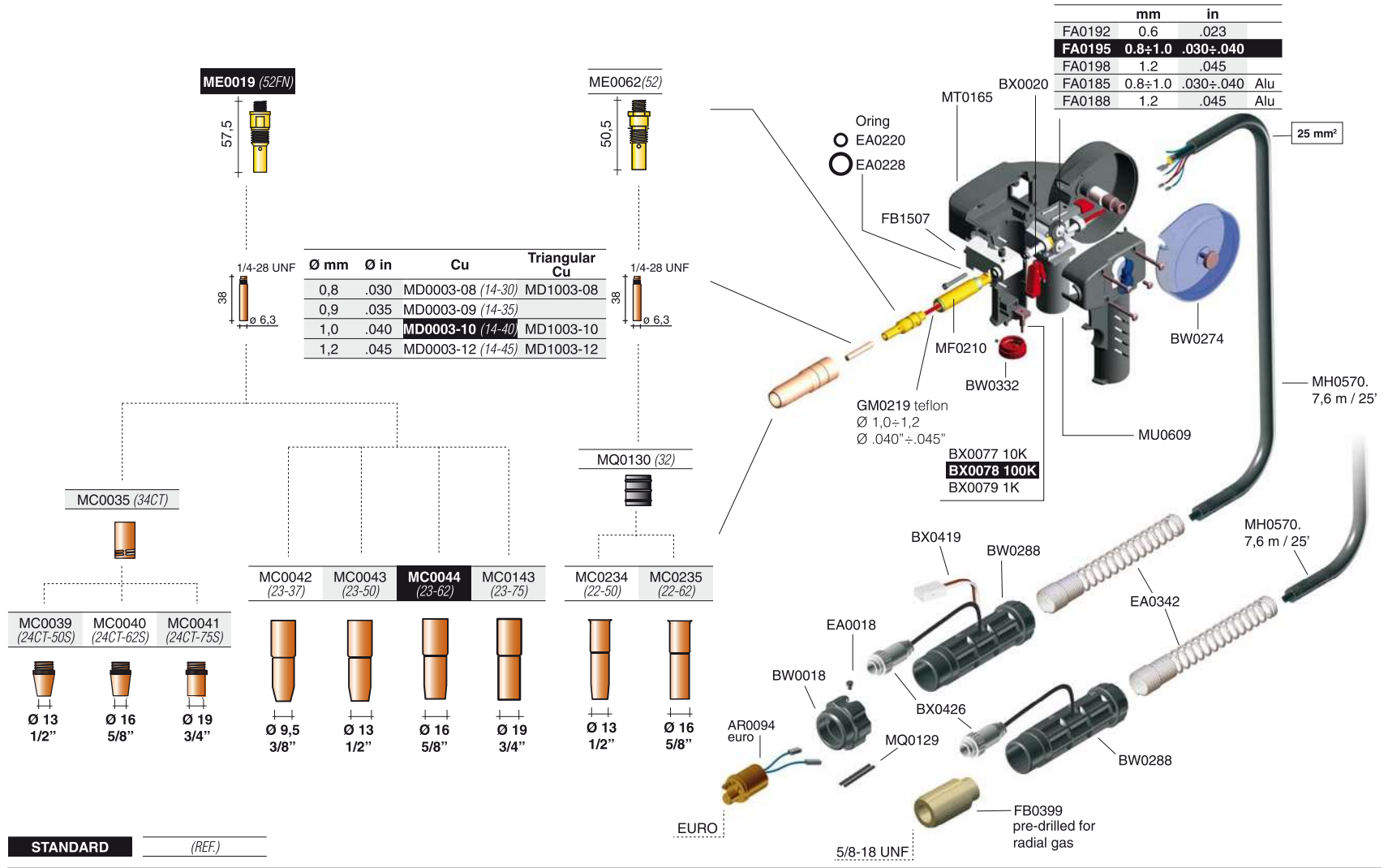

STANDARD (REF)