

# Athlete

*High Speed, High Accuracy, Best Quality*



● Athlete 1530 with fume collection table

**Athlete** is the high speed, high precision CNC cutting machine which can integrate with HyDefinition plasma cutting system to perform the best cutting quality.

Compact design require minimum floor space and provide quick installation, friendly operation, and "Put & Cut" application!

## Features:

- All-in-one compact design including gantry, fume collection duct and table
- MicroEDGE Pro controller from USA
- Precision Rack and Pinion on dual drive
- Double linear way in transverse and longitudinal axis
- High efficiency sequential zone fume collection table ready for use
- For 1 Plasma only (HyDefinition model is recommended)
- Easy installation and minimum setup time



● MicroEDGE Pro CNC controller

**Standard Accessories:**



- MicroEDGE Pro with 15" touch screen advanced & stable



- Precision linear way with copper plug for durable lifetime



- Sequential zone downdraft table with unique air flow passage

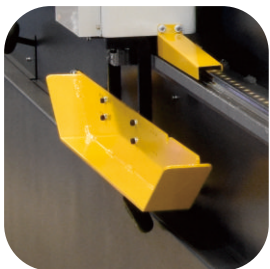

- Mechanical duct-gate Without electrical parts Maintenance free!

**Optional Accessories:**

- PC-055 ProArc Sensor THC
- PC-047 Anti-collision device
- PC-026 Mechanical height control
- PC-024 Pneumatic sheet clamp
- PC-007 Laser point positioning unit
- ProArc Dust Collector with inverter fan
- Water table available



● ProArc Total Cutting Solution

Specification				
Model	Unit	Athlete 15	Athlete 20	Athlete 25
Power input		AC 220 / 380V, 50 / 60Hz, 3 phase		
Travel drive method		Precision rack & pinion		
Travel rail		Double linear way		
Overall width (A)	mm	2,250	2,550	3,155
Overall height (B)	mm	1,600		
Overall length (C)	mm	4,150 (7,350)		
Cutting width (D)	mm	1,600	1,900	2,500
Cutting length (E)	mm	3,100 (6,200)		
Cutting speed	m/min	16		
Travel speed	m/min	24		
Positioning accuracy	mm	± 0.1		
Repeatability	mm	± 0.05		
Machine weight	kg	1,570	1,750	1,950

\*Specifications subject to change without notice

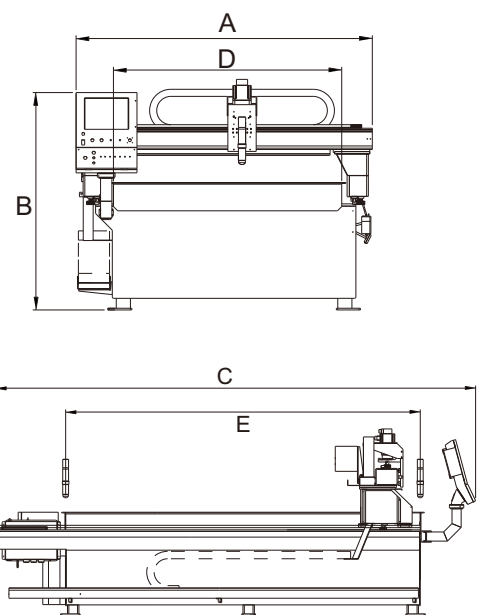

**UNITED PROARC CORPORATION**

No.3 Gungye 10th Rd., Pingjen Industrial Park, Pingjen Dist., Taoyuan City 32459, Taiwan  
 Phone: +886 3 469 6600 Fax: +886 3 4694499  
 E-mail: [sales@proarc.com.tw](mailto:sales@proarc.com.tw) <http://www.proarc.com.tw>